

COMTEC[®] 6000 System Overview

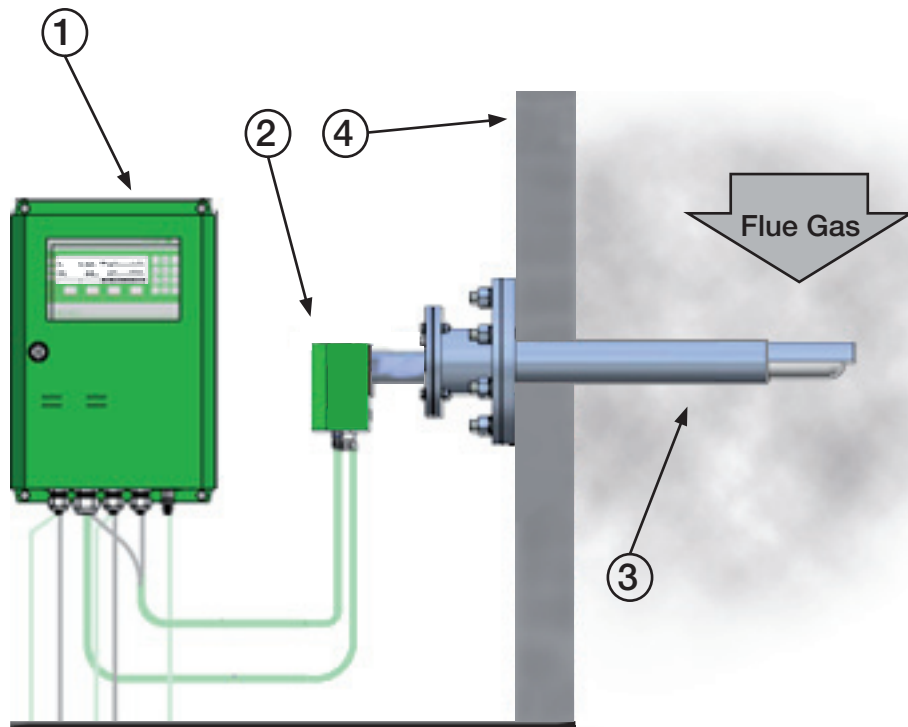

DESCRIPTION

- 1 - Electronic unit
- 2 - Probe connection box
- 3 - Probe
- 4 - Duct wall

COMTEC[®] 6000

System Overview

with cooling protection tube

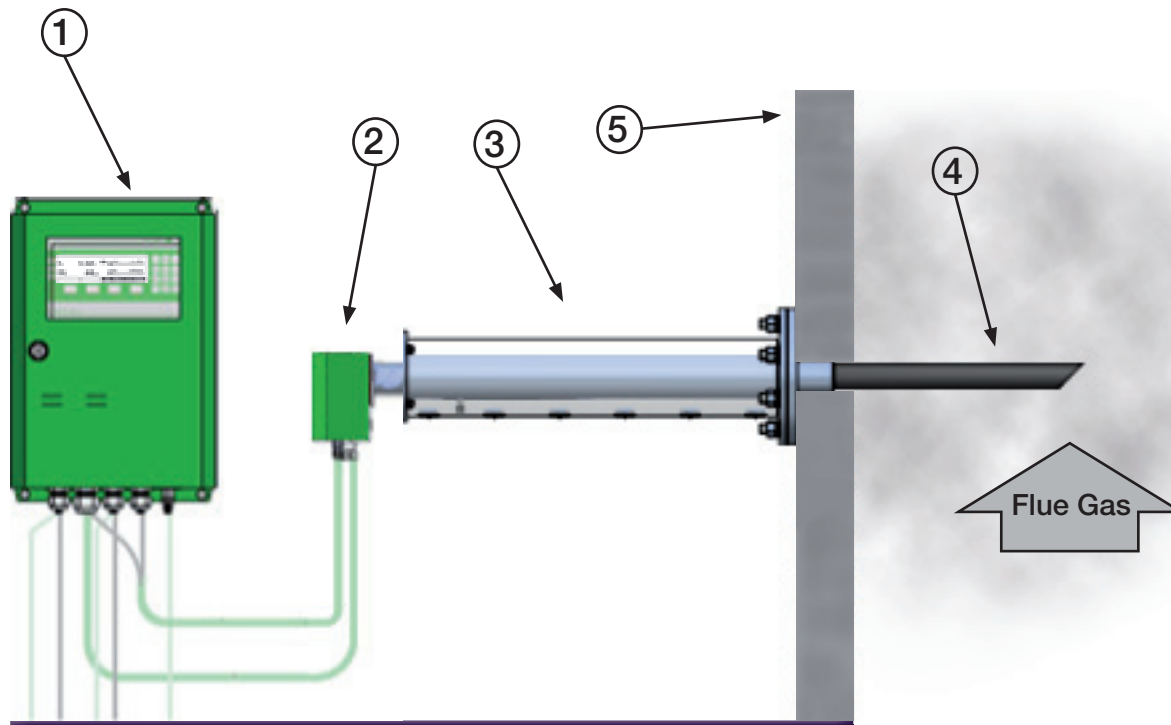

DESCRIPTION

- 1 - Electronic unit
- 2 - Probe connection box
- 3 - Probe with insulation jacket*
- 4 - Cooling protection tube
- 5 - Duct wall

* The part of the protection tube projecting from the duct wall must be insulated if necessary, to prevent its temperature from dropping below the dew point.