

## Model 405 nm NO<sub>2</sub>/NO/NO<sub>x</sub> Monitor™

Direct Measurement of NO<sub>2</sub> by Absorbance

*Federal Equivalent Method (FEM) for NO<sub>2</sub>*



The Model 405 nm NO<sub>x</sub> Monitor ("nm" for "nanometer" and for "NO<sub>x</sub> Monitor") is designed for the direct measurement of atmospheric nitrogen dioxide (NO<sub>2</sub>), nitric oxide (NO) and total reactive oxides of nitrogen (NO<sub>x</sub> = NO + NO<sub>2</sub>) in the concentration range 0-10,000 ppb (0-10 ppm) for NO<sub>2</sub> and 0-2,000 ppb (0-2 ppm) for NO with high precision and accuracy. In this instrument NO<sub>2</sub> is measured directly by absorbance at 405 nm. NO is measured by selective conversion with ~100% efficiency using the highly selective reaction of NO with ozone (O<sub>3</sub>). Total NO<sub>x</sub> is obtained by addition of NO and NO<sub>2</sub>.

Unlike chemiluminescence instruments where NO<sub>2</sub> must be converted to NO using either a molybdenum or photolytic converter with highly variable efficiency, in the Model 405 NO<sub>x</sub> Monitor nitrogen dioxide is measured directly by absorbance, analogous to an ozone monitor. Because NO<sub>2</sub> has a much lower absorption cross section than ozone, a folded cell with corner mirrors is used to produce a long absorbance path of ~2 m to achieve approximately the same sensitivity for NO<sub>2</sub> as we do for ozone in our UV-absorbance-based ozone monitors. (See our [published paper](#) on the folded tubular photometer.) The wavelength of 405 nm was chosen because no other species found in ambient air has significant absorbance at that wavelength, making the Model 405 nm extremely selective for NO<sub>2</sub>.

The Model 405 nm NO<sub>x</sub> Monitor is approved as a U.S. EPA Federal Equivalent Method (FEM) for the criteria pollutant NO<sub>2</sub>, [EQNA-0217-243](#). SD card data logging is now a standard feature.

## Theory of Operation

The following figure is a simplified schematic diagram of the Model 405 nm NO<sub>x</sub> Monitor. Sample air is continuously drawn through the instrument by an air pump at a flow rate of ~2 L/min. The Scrubber Valve alternately bypasses and sends the sample air through a NO<sub>2</sub> scrubber to remove all NO<sub>2</sub> in the sample, thus allowing the measurement of a light intensity in the absence (I<sub>0</sub>) of NO<sub>2</sub> and presence (I) of NO<sub>2</sub>. The Beer-Lambert Law is then used to calculate the concentration of NO<sub>2</sub> from I and I<sub>0</sub>.

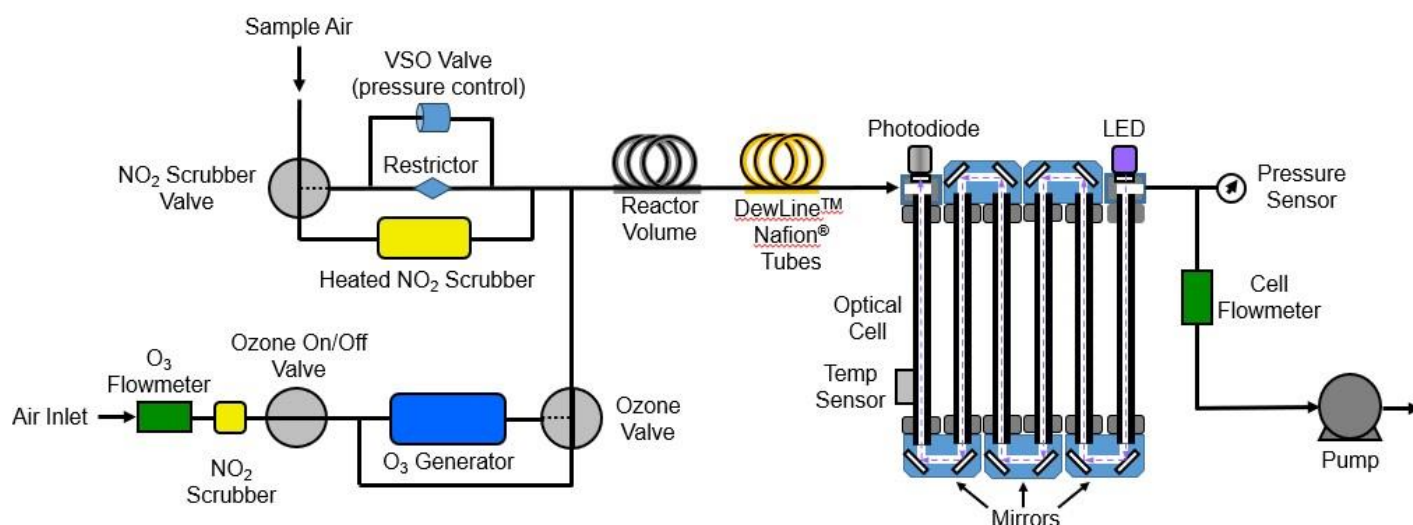

**Fig. 1.** Simplified schematic diagram of the Model 405 nm NO<sub>2</sub>/NO/NO<sub>x</sub> Monitor.

Nitric oxide is measured by bypassing the NO<sub>2</sub> Scrubber and measuring the light intensity while adding (I) or not adding (I<sub>0</sub>) ozone to convert NO to NO<sub>2</sub> according to the reaction:

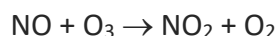

As in our ozone monitors and our Model 410 NO Monitor, a Nafion tube (the DewLine™) is used to equilibrate humidity during I and I<sub>0</sub> measurements, so that any water vapor interference due to refractive effects is eliminated.

NO<sub>x</sub> is obtained by adding the measurements of NO<sub>2</sub> and NO. The instrument may be operated in continuous NO<sub>2</sub>, or NO mode, or in a mode where NO<sub>2</sub> and NO are alternately measured, once every 20 seconds.

## Features

- Direct measurement of NO<sub>2</sub> (absorbance at 405 nm) gives extreme selectivity for NO<sub>2</sub>
- Measurement of NO<sub>2</sub> over the range 0-10 ppm, NO over the range 0-2 ppm, and NO<sub>x</sub>
- FEM for NO<sub>2</sub> over the range 0-500 ppb and 20-30°C operating temperature range
- Three measurement modes: NO<sub>2</sub> only; NO only; NO, NO<sub>2</sub>, and NO<sub>x</sub>
- Power consumption: ~16 watts after warmup
- Long-life pump (~15,000 hours)
- Flash memory (SD card) for virtually unlimited, portable data logging
- Internal data logger (EEPROM) logs 8,192 lines of data
- Both serial and user-scalable analog voltage outputs for NO and NO<sub>2</sub>
- Convenient user interface to microprocessor, including calibration parameters (gain and zero)
- Selectable measurement time of 5 s or data averaging times of 1 min, 5 min and 1 hr
- Selectable units for NO<sub>2</sub>, NO, NO<sub>x</sub>
- DewLine™ for elimination of any water vapor interference, a unique feature of 2B Tech instruments

## Options

- Bluetooth for wireless data transmission
- Serial-to-USB converter

## Specifications

<b>Principle of Measurement</b>	Direct absorbance of NO <sub>2</sub> at 405 nm
<b>Certifications</b>	U.S.: EPA Federal Equivalent Method (FEM) for NO <sub>2</sub> (0-500 ppb, 20-30°C), <a href="#">EQNA-0217-243</a> CE
<b>Measurement Modes</b>	NO <sub>2</sub> only; NO only; NO, NO <sub>2</sub> and NO <sub>x</sub>
<b>Linear Dynamic Range</b>	0-10,000 ppb (0-10 ppm) for NO <sub>2</sub> ; 0-2,000 ppb (0-2 ppm) for NO. FEM-approved for 0-500 ppb NO <sub>2</sub> from 20-30°C.
<b>Resolution</b>	0.1 ppb
<b>Precision (1σ; rms noise)</b>	< 0.5 ppb or 0.5% of reading (with adaptive filter <sup>1</sup> )
<b>Accuracy</b>	Greater of 2 ppb or 2% of reading
<b>Limit of Detection (2σ)</b>	< 1 ppb (with adaptive filter <sup>1</sup> )
<b>Flow Rate (nominal)</b>	1.5 Liter/min
<b>Flow Rate Requirement</b>	Minimum: 1.4 Liter/min; Maximum: 1.6 Liter/min
<b>Response Time, 100% of Step Change</b>	10 s for 5-s averaging 20 s with adaptive filter <sup>1</sup>
<b>Measurement Frequency</b>	0.2 Hz (once every 5 s)
<b>Averaging Times</b>	5 s, 1 min, 5 min, 1 hr

<b>SD Data Logger Capacity</b>	Minimum 2 GB (>2-year capacity for 5-s measurement mode)
<b>Internal Data Logger Capacity</b>	8,192 lines (5-s avg = 0.47 days; 1-min avg = 5.7 days; 5-min avg = 1.0 mo; 1-hr avg = 0.94 yr)
<b>Concentration Units</b>	ppb, pphm, ppm
<b>Pressure, Temperature Units</b>	mbar, °C
<b>T and P Corrected</b>	Yes
<b>Operating Temperature Range</b>	10 to 50°C (FEM approval for NO <sub>2</sub> for 20-30°C)
<b>Power Requirement</b>	11-14 V dc or 120/240 V ac, 1.4 A at 12 V, 17 watt Max: 2.9 A at 12 V, 35 watt (warmup)
<b>Size</b>	Rackmount: 17" w × 14.5" d × 5.5" h (43 × 37 × 14 cm)
<b>Weight</b>	18.6 lb. (8.4 kg)
<b>Data Outputs</b>	LCD; RS232; SD card; 0-2.5 V Analog Outputs for NO and for NO <sub>2</sub>
<b>Data Transfer Baud Rates</b>	2400, 4800, 19200
<b>Output Ranges</b>	User-defined scaling factor in menu
<b>DewLine™</b>	Yes
<b>Long Life Pump</b>	Yes: 15,000 hr, 1.7 yr of continuous operation
<b>Flow Meter</b>	Yes
<b>Options</b>	Bluetooth for wireless data transmission; USB output (in place of RS232); touchscreen

<sup>1</sup> An adaptive filter may be selected from the menu, making signal averaging similar to competing NO<sub>x</sub> monitors. Specifications above are for default parameters: Change Difference = 40 ppb, Change Percent = 10%, Short Filter = 4 pts (20 s), Long Filter = 36 pts (3 min). Adaptive filter parameters may be adjusted by the user.

## System Includes

- Model 405 nm NO<sub>2</sub>/NO/NO<sub>x</sub> Monitor
- 5A Power Adapter (5 amp, 100-240 VAC to 12 VDC) with select power cord
- Serial Port Cable (9PinF-9PinF)
- External (Zero) Nafion Assembly
- SD Card and SD Card Reader
- Operation Manual on USB Stick
- Calibration Data and NIST-Traceable Calibration Certificate
- Instrument Birth Certificate
- One-Year Warranty