

Personal Ozone Monitor™ Model POM™

2B *Technologies, Inc.*

OPERATION MANUAL

© Copyright 2014, 2B Technologies, Inc.
All rights reserved.

TABLE OF CONTENTS

<i>IDENTIFICATION RECORDS</i>	iii
<i>PRINTING HISTORY</i>	iv
<i>WARRANTY STATEMENT</i>	v
<i>WARNINGS</i>	vii
<i>PERSONAL OZONE MONITOR INTRODUCTION</i>	1
<i>SPECIFICATIONS</i>	5
<i>OPERATION</i>	7
<i>GPS</i>	9
<i>FRONT PANEL MENU</i>	11
<i>LOGGING DATA</i>	13
<i>LAMP TEST</i>	18
<i>SERIAL MENU</i>	19
<i>MAINTENANCE/TROUBLESHOOTING</i>	20
<i>CALIBRATION</i>	23
<i>LABELLED PARTS</i>	29
<i>PARTS LIST</i>	32
<i>SERVICE LOG</i>	33
<i>USB INSTALLATION</i>	35
<i>USING THE USB CONNECTION</i>	39

IDENTIFICATION RECORDS

Record the following information for future reference:

Serial number: _____

Warranty start date: _____
(date of receipt)

PRINTING HISTORY

New editions are complete revisions of the manual and incorporate all previous update pages and write-in instructions. This manual will be revised as necessary. Revisions can be in the form of new editions, update pages, or write-in instructions.

Revision A..... March 2012

Revision B.....January 2014

Revision C..... February 2014

TRADEMARKS & PATENTS

2B Technologies™, 2B Tech™, 2B™, Personal Ozone Monitor™ and POM™ are trademarks of 2B Technologies, Inc.

CONFIDENTIALITY

The information contained in this manual may be confidential and proprietary, and is the property of 2B Technologies, Inc. Information disclosed herein shall not be used to manufacture, construct, or otherwise reproduce the goods disclosed herein. The information disclosed herein shall not be disclosed to others or made public in any manner without the expressed written consent of 2B Technologies, Inc.

© Copyright 2012, 2B Technologies, Inc.
All rights reserved.

WARRANTY STATEMENT

2B Technologies, Inc. warrants its products against defects in materials and workmanship. 2B Technologies will, at its option, repair or replace products which prove to be defective. The warranty set forth is exclusive and no other warranty, whether written or oral, is expressed or implied. 2B Technologies specifically disclaims the implied warranties of merchantability and fitness for a particular purpose.

Warranty Periods

The warranty period is one (1) year from date of receipt by the purchaser, but in no event more than thirteen (13) months from original invoice date from 2B Technologies, Inc.

Warranty Service

Warranty Service is provided to customers via web ticket, email and phone support, Monday - Friday, from 9:00 a.m. to 5:00 p.m., Mountain Time USA. The preferred method of contacting us is through our web ticketing software at:

www.twobtech.com/techsupport

This way all technical staff at 2B Tech will be alerted of your problem and be able to respond. When you receive an email reply, please click on the Ticket link provided to continue to communicate with us directly over the internet. The web ticket approach to customer service allows us to better track your problem and be certain that you get a timely response. We at 2B Tech pride ourselves on the excellent customer service we provide.

You may also contact us by email at techsupport@twobtech.com or by phone at +1(303)273-0559. In either case, a web ticket will be created, and future communications with you will be through that ticket.

Initial support involves trouble-shooting and determination of parts to be shipped from 2B Technologies to the customer in order to return the product to operation within stated specifications. If such support is not efficient and effective, the product may be returned to 2B Technologies for repair or replacement. Prior to returning the product, a Repair Authorization Number (RA) must be obtained from the 2B Technologies Service Department. We will provide you with a simple Repair Authorization Form to fill out to return with the instrument.

Shipping

2B Technologies will pay freight charges for replacement or repaired products shipped to the customer site. Customers shall pay freight charges for all products returning to 2B Technologies.

Conditions

The foregoing warranty shall not apply to defects resulting from improper or inadequate maintenance, adjustment, calibration or operation by customer. Maintenance, adjustment, calibration or operation must be performed in accordance with instructions stated in this manual. Usage of maintenance materials purchased from suppliers other than 2B Technologies will void this warranty.

Limitation of Remedies and Liability

The remedies provided herein are the Customer's sole and exclusive remedies. In no event shall 2B Technologies be liable for direct, indirect, special, incidental or consequential damages (including loss of profits) whether based on contract, tort or any other legal theory. The Personal Ozone Monitor manual is believed to be accurate at the time of publication and no responsibility is taken for any errors that may be present. In no event shall 2B Technologies be liable for incidental or consequential damages in connection with or arising from the use of the Personal Ozone Monitor manual and its accompanying related materials. Warranty is valid only for the country designated on the 2B Technologies quote or invoice.

Warnings

ENGLISH



WARNING:
Any operation requiring access to the inside of the equipment, could result in injury. To avoid potentially dangerous shock, disconnect from power supply before opening the equipment.

WARNING:

This symbol, , on the instrument indicates that the user should refer to the manual for operating instructions.

WARNING:

If this instrument is used in a manner not specified by 2B Technologies, Inc. USA, the protection provided by the instrument may be impaired.

ESPAÑOL



ATENCIÓN:
Cualquier operación que requiera acceso al interior del equipo, puede causar una lesión. Para evitar peligros potenciales, desconectarlo de la alimentación a red antes de abrir el equipo.

ATENCIÓN:

Este símbolo, , en el instrumento indica que el usuario debería referirse al manual para instrucciones de funcionamiento.

ATENCIÓN:

Si este instrumento se usa de una forma no especificada por 2B Technologies, Inc., USA, puede desactivarse la protección suministrada por el instrumento.

FRANÇAIS



ATTENTION:
Chaque opération à l'intérieur de l'appareil, peut causer du préjudice. Afin d'éviter un shock qui pourrait être dangereux, déconnectez l'appareil du réseau avant de l'ouvrir.

ATTENTION:

Le symbol, , indique que l'utilisateur doit consulter le manuel d'instructions.

ATTENTION:

Si l'instrument n'est pas utilisé suivant les instructions de 2B Technologies, Inc., USA, les dispositions de sécurité de l'appareil ne sont plus valables.

DEUTSCH



WARNHINWEIS:
Vor dem Öffnen des Gerätes Netzstecker ziehen!

WARNHINWEIS:

Dieses, , auf dem Gerät weist darauf hin, daß der Anwender zuerst das entsprechende Kapitel in der Bedienungsanleitung lesen sollte.

WARNHINWEIS:

Wenn das Gerät nicht wie durch die Firma 2B Technologies, Inc., USA, vorgeschrieben und im Handbuch beschrieben betrieben wird, können die im Gerät eingebauten Schutzvorrichtungen beeinträchtigt werden.

ITALIANO



ATTENZIONE:
Qualsiasi intervento debba essere effettuato sullo strumento può essere potenzialmente pericoloso a causa della corrente elettrica. Il cavo di alimentazione deve essere staccato dallo strumento prima della sua apertura.

ATTENZIONE:

Il simbolo, , sullo strumento avverte l'utilizzatore di consultare il Manuale di Istruzioni alla sezione specifica.

ATTENZIONE:

Se questo strumento viene utilizzato in maniera non conforme alle specifiche di 2B Technologies, Inc. USA, le protezioni di cui esso è dotato potrebbero essere alterate.

DUTCH



OPGELET:
Iedere handling binnenin het toestel kan beschadiging veroorzaken. Om iedere mogelijk gevaarlijke shock te vermijden moet de aansluiting met het net verbroken worden, vóór het openen van het toestel.

OPGELET:

Het symbol, , geeft aan dat de gebruiker de instructies in de handleiding moet raadplegen.

OPGELET:

Indien het toestel niet gebruikt wordt volgens de richtlijnen van 2B Technologies, Inc., USA gelden de veiligheidsvoorzieningen niet meer.

PERSONAL OZONE MONITOR INTRODUCTION

The 2B Technologies Personal Ozone Monitor (POM) is designed to enable accurate measurements of ozone in air over a wide dynamic range extending from a limit of detection of 4 parts-per-billion by volume (ppb) to an upper limit of 10 parts-per-million (ppm) based on the well established technique of absorption of ultraviolet light at 254 nm. Note that throughout this manual and in the instrument output, "ppb" (identical to "ppbv") refers to parts-per-billion by volume (not weight). The Personal Ozone Monitor is small (4.0" × 3.0" × 1.5", 10.2 x 7.6 x 3.9 cm), light weight (0.75 lb., 0.34 kg.) and has a low power consumption (3.0 watt) relative to conventional instruments and is therefore well suited for applications such as:

- long-term monitoring at remote locations where power is highly limited
- monitoring and control of ozone in industrial settings
- monitoring of exposure to individuals in the workplace
- personal exposure monitoring for studies of health effects of air pollutants

For aircraft flights where high temporal and spatial resolution is desired, the Model 205 Ozone Monitor is recommended.

Theory of Operation

Absorption of UV light has long been used for measurements of atmospheric ozone with high precision and accuracy. The ozone molecule has an absorption maximum at 254 nm, coincident with the principal emission wavelength of a low-pressure mercury lamp. Fortunately, few molecules found at significant concentrations in the atmosphere absorb at this wavelength. However, interferences, such as organic compounds containing aromatic rings, can occur in highly polluted air.

Figure 1 is a schematic diagram of the Personal Ozone Monitor. Ozone is measured based on the attenuation of light passing through a 15-cm absorption cell fitted with quartz windows. The 15-cm cell length is accomplished by using a "U" shaped cell with mirrors in the corners to transmit light from the lamp at one end to the detector at the other. A low-pressure mercury lamp is located on one side of the absorption cell, and a photodiode is located on the opposite side of the absorption cell. The photodiode has a built-in interference filter centered on 254 nm, the principal wavelength of light emitted by the mercury lamp. An air pump draws sample air into the instrument at a flow rate of

approximately 0.75 L/min. A solenoid valve switches so as to alternately send this air directly into the absorption cell or through an ozone scrubber and then into the absorption cell. The intensity of light at the photodiode is measured in air that has passed

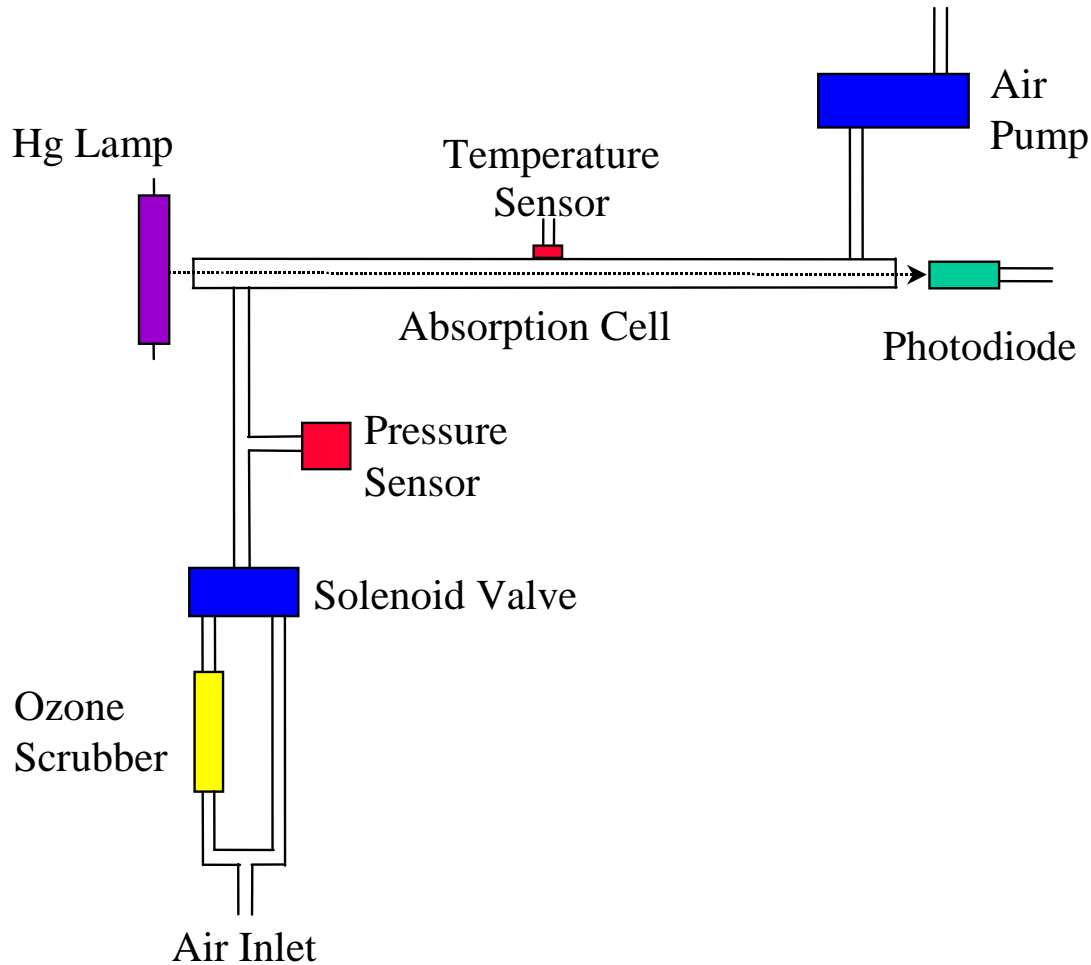

Figure 1. Schematic Diagram of the Personal Ozone Monitor.

through the ozone scrubber (I_o) and air that has not passed through the scrubber (I). Ozone concentration, $[O_3]$, in units of molecules/cm³ is calculated from the measurements of I_o and I according to the Beer-Lambert Law:

$$[O_3] = \frac{1}{\sigma l} \ln \left(\frac{I_o}{I} \right) \quad (1)$$

where l is the path length (15 cm) and σ is the absorption cross section for ozone at 254 nm ($1.15 \times 10^{-17} \text{ cm}^2 \text{ molecule}^{-1}$ or $308 \text{ atm}^{-1} \text{ cm}^{-1}$), which is known with an accuracy of approximately 1%. The 2B Technologies instrument

uses the same absorption cross section (extinction coefficient) as used in other commercial instruments.

In order to convert this concentration to a mixing ratio (fraction of total air molecules that are ozone, we also measure the cell temperature and pressure, which determines the total concentration of air molecules. From the temperature and pressure we use the ideal gas law to calculate the concentration of molecules, M , in the detection cell. Ozone in units of ppb is then given by:

$$[O_3]_{ppb} = 10^9 \frac{[O_3]}{[Air]} = 10^9 \frac{N_A RT}{P l \sigma} \ln \left(\frac{I_0}{I} \right) \quad (2)$$

Where N_A is Avagadro's number ($6.02214129 \times 10^{23}$ molec/mol), R is the gas constant ($82.05746 \text{ cm}^3 \text{ atm K}^{-1} \text{ mol}^{-1}$), T is the absolute temperature in K, and P is the cell pressure in atmospheres.

The instrument displays and records the cell temperature and pressure in addition to the ozone mixing ratio. The cell pressure is displayed and logged in units of mbar or torr and the cell temperature in units of either °C or K.

In principle, the measurement of ozone by UV absorption requires no external calibration; it is an absolute method. However, non-linearity of the photodiode response and electronics can result in a small measurement error. Therefore, each instrument is compared with a NIST-traceable standard ozone spectrophotometer in the laboratory over a wide range of ozone mixing ratios. These results are used to calibrate the POM with respect to an offset and slope (gain or sensitivity). The corrections for offset and slope are recorded in the instrument Birth Certificate. These calibration parameters are entered into the microprocessor prior to shipment. The user may change the calibration parameters from the front panel if desired. It is recommended that the instrument be recalibrated at least once every year and preferably once every six months. The offset may drift due to temperature change or chemical contamination of the absorption cell. As discussed below, an accurate offset correction can be measured from time to time using the external ozone scrubber (Zeroing Cartridge) supplied with the instrument.

Not shown on Fig. 1 is the DewLine™, which serves to make the humidity entering the detection cell identical during I and I_0 measurements. Please see our website for a technical discussion of the DewLine™ and its importance to ozone measurements: www.twobtech.com/dewline.htm. Briefly, water vapor adsorbed to the inner wall of the detection cell changes the reflectivity of the cell. If humidity is not the same during I and I_0 measurements, an offset in the ozone measurement will occur and can be up to several tens of ppb for sudden changes in ambient humidity. The offset will change with time as the internal

ozone scrubber equilibrates with water vapor. Even for fixed-site ozone monitors an offset measurement error will occur if the instrument is zeroed with dry tank air and then used to measure ozone in humid air. The DewLine™ solution to this often ignored problem is unique to 2B Tech instruments.

SPECIFICATIONS



2B Tech has taken the next step in miniaturization of UV-based ozone monitors by developing the Personal Ozone Monitor or "POM". The POM has dimensions of 4 x 3 x 1.5 inches and weighs only 0.75 lb (340 g). It has a built in GPS so that ozone measurements may be logged continuously along with geographic location. By folding the optical path in the shape of a "U", it was possible to achieve the same path length in the POM as in the Models 202, 205 and 106-L and thus have similar precision and accuracy (~2 ppb).

- Personal exposure monitoring for studies of health effects of air pollutants
- Health and safety monitoring at industrial sites using ozone
- Vertical profiling using balloons, kites, RPVs and light aircraft where space and weight are highly limited
- Long-term monitoring at remote locations where power is highly limited
- Urban arrays of ground-based detectors

Personal Ozone Monitor Specifications

Measurement Principle	UV Absorption at 254 nm
Linear Dynamic Range	2 ppb to 10 ppm
Resolution	0.1 ppb
Precision (1σ; rms noise)	Greater of 2 ppb or 2% of reading
Accuracy	Greater of 2 ppb or 2% of reading
Limit of Detection (2σ)	4 ppb

NIST-Traceable Calibration	Yes
Measurement Interval	10 s (Data averaging options: 10 s, 1 min, 5 min, 1 hr)
Flow Rate (nominal)	~0.8 Liter/min
Flow Rate Requirement	>0.5 L/min
Baseline Drift	<2 ppb/day <5 ppb/year
Sensitivity Drift	<1%/day <3%/year
Measurement Time, Frequency	10 s, 0.1 Hz
Response Time, 100% of Step Change	20 s, 2 points
Averaging Times	10 s, 1 min, 5 min, 1 hr
Data Storage	8,192 lines (10 s avg ~1 day; 1 min avg ~1 wk; 5 min ~1 mo; 1 hr avg ~1 yr)
Ozone Units	ppb, ppm, pphm, $\mu\text{g m}^{-3}$, mg m^{-3}
Pressure Units	mbar, torr
Temperature Units	°C, K
T and P Corrected	Yes
Operating Temperature Range	0 to 50 °C
Power Requirement; Supplied by battery or 110/220 VAC Power Pack	7-14 V dc, nominally 250 mA at 12 V, 3.0 watt
External Battery	7.4 Volt, 1.6 amp hour, Lithium Polymer Battery, 5-8 hr
Size	4.0 x 3.0 x 1.5 inches (10.2 x 7.6 x 3.8 cm)

OPERATION

Please read all the following information before attempting to install the Personal Ozone Monitor. For assistance, please call 2B Technologies at (303)273-0559.

NOTE:

Save the shipping carton and packing materials that came with the Personal Ozone Monitor. If the Personal Ozone Monitor must be returned to the factory, pack it in the original carton. Any repairs as a result of damage incurred during shipping will be charged.

Shipping Box Contents

Open the shipping box and verify that it contains all of the items on the shipping list. If anything is missing or obviously damaged, contact 2B Technologies immediately.

Operation of the Personal Ozone Monitor

To operate the Personal Ozone Monitor, connect it to an external power source and power the instrument by switching the power switch on. The instrument requires a 7-24 V DC source which can be supplied by: 1) the 100-240 V AC power adapter, 2) a cigarette lighter adapter plugged into a 12 V DC source such as found in an automobile or many light aircraft, or 3) a 7-24 V battery. The source can be in the range 7-24 V DC without any detrimental effects on the measurement. When using a battery, be certain to attach the positive (red) and negative (black) wires correctly. Batteries and battery chargers are available from 2B Technologies. A circuit breaker and diode are installed on the circuit board in case of an electrical short or incorrect battery attachment. If activated, the breaker will reset itself after a few minutes.

Once turned on, the instrument will display the version number of the software installed on the microprocessor. After a few seconds, the instrument will start displaying readings for ozone. The first dozen readings (requiring about two minutes) will be spurious, with large positive and negative swings due to the rapid warmup of the lamp and electronics. Also, ozone readings may be

inaccurate during the 10-20 minutes required for the lamp, photodiode, and internal temperature of the absorption cell to stabilize.

Inlet tubing may be attached to the white fitting on the front of the instrument. The inlet tubing should be made of PTFE (Teflon[®]), PFA, FEP, PVDF or some other inert material that does not destroy ozone and that does not desorb plasticizers and other organics that can contaminate the flow path. The length of tubing should be kept as short as possible (preferably not more than a few feet) to minimize ozone destruction within the inlet tubing. Tygon[®], polypropylene (which may look like Teflon) and metal tubing should not be used. FEP-lined Tygon tubing, which is used inside the instrument provides the flexibility of Tygon with the inertness of FEP. A Teflon or PVDF inlet filter is highly recommended to prevent internal contamination of the tubing and absorption cell by particulate matter. The filter should be tested for ozone loss by measuring ambient ozone with and without the filter attached. Filters and filter holders are available through 2B Technologies.

Although the instrument compensates for temperature drift, if strong temperature fluctuations are expected, as in vertical profiling applications using balloons, the instrument should be placed in a thermally insulated box.

Measurement of the Zero Offset

The electronic zero of the instrument may be measured by attaching an ozone zeroing scrubber (part no. ZEREXTPOM or other ozone destruction cartridge) to the air inlet for a period of 5-10 minutes. For an accurate measurement, the instrument must have been turned on long enough for the internal temperature to stabilize. The observed offset, which can amount to \pm a few ppb, can be corrected for by changing the offset calibration parameter (Z) from the front panel, as described below.

Collecting Data over the Serial Port in Real Time

To transmit data to a computer over the serial port in real time, connect the Personal Ozone Monitor to the serial port of the computer using the stereo plug to D9 serial cable provided. Start your data acquisition software, preferably using the 2B Technologies Display and Graphing Software (free download from <http://twobtech.com/software.htm>). Other terminal emulation software such as HyperTerminal (a program provided with Windows) or [Tera Term Pro](#) may be used as well.

The ozone mixing ratio, internal cell temperature, cell pressure, time and date are sent as comma-delimited ASCII text to the serial and USB ports (19200 baud as selected in menu; 8 bits; no parity; 1 stop bit) every ten seconds, 1 minute, 5 minutes, or 1 hour, depending on the averaging time selected from the microprocessor menu. Time is provided in 24-hour (military) format, and the date is given in European style (day/month/year).

A typical data line would read:

3.2,307.4,608.1,1.2740,12.1,4001.27765,-10513.0308,1591.20,1,23/03/12,16:39:14

where:

Ozone = 3.2 ppb

Cell temperature = 307.4 K

Cell pressure = 608.1 torr (1 atm = 760 torr)

Photodiode Voltage = 1.2740 volts

Power Supply Voltage = 12.1 volts

Latitude = 4001.27765

Longitude = -10513.0308

Altitude = 1591.20

GPS Quality = 1

Date = March 23, 2012

Time = 4:39:14 pm

If outputting logged data, the output serial data line will be preceded by the log number; e.g.,

2893,3.2,307.4,608.1,1.2740,12.1,4001.27765,-10513.0308,1591.20,1,23/03/12,16:39:14

where 2893 is the log number.

In addition to data lines, messages are written to the serial port when logging is begun or ended, when transmission of data from the logger is begun and ended, when data collection is interrupted (e.g., due to a power failure) and when the averaging time is changed.

GPS

The POM contains an on-board GPS unit which incorporates the well known u-blox 6 GPS position engine and an efficient antenna system to provide highly accurate and precise location data with each ozone measurement.

To acquire satellite signals, go outdoors away from tall buildings and trees. Acquiring satellite signals may take 1-5 minutes. For best results, stand still in an open area with POM powered on until an asterisk appears on the LCD as shown below. The **asterisk** denotes a valid satellite connection.

*** O3= 2.7 ppb
T=31.4 P=982.3**

As described in the section “Viewing GPS coordinates via the front panel” below, it is possible to view the GPS data in real time on the LCD by navigating to the “GPS” submenu. GPS coordinates, along with the GPS quality indication are also logged with each measurement when the POM is set to log.

The **GPS quality indication** can be translated as: 0 = fix not available, 1 = Non-differential GPS fix available, 2 = Differential GPS (WAAS) fix available, and 6 = Estimated.

FRONT PANEL MENU

The following diagram summarizes the complete instrument Menu accessed via the LCD, Select, and Move buttons.

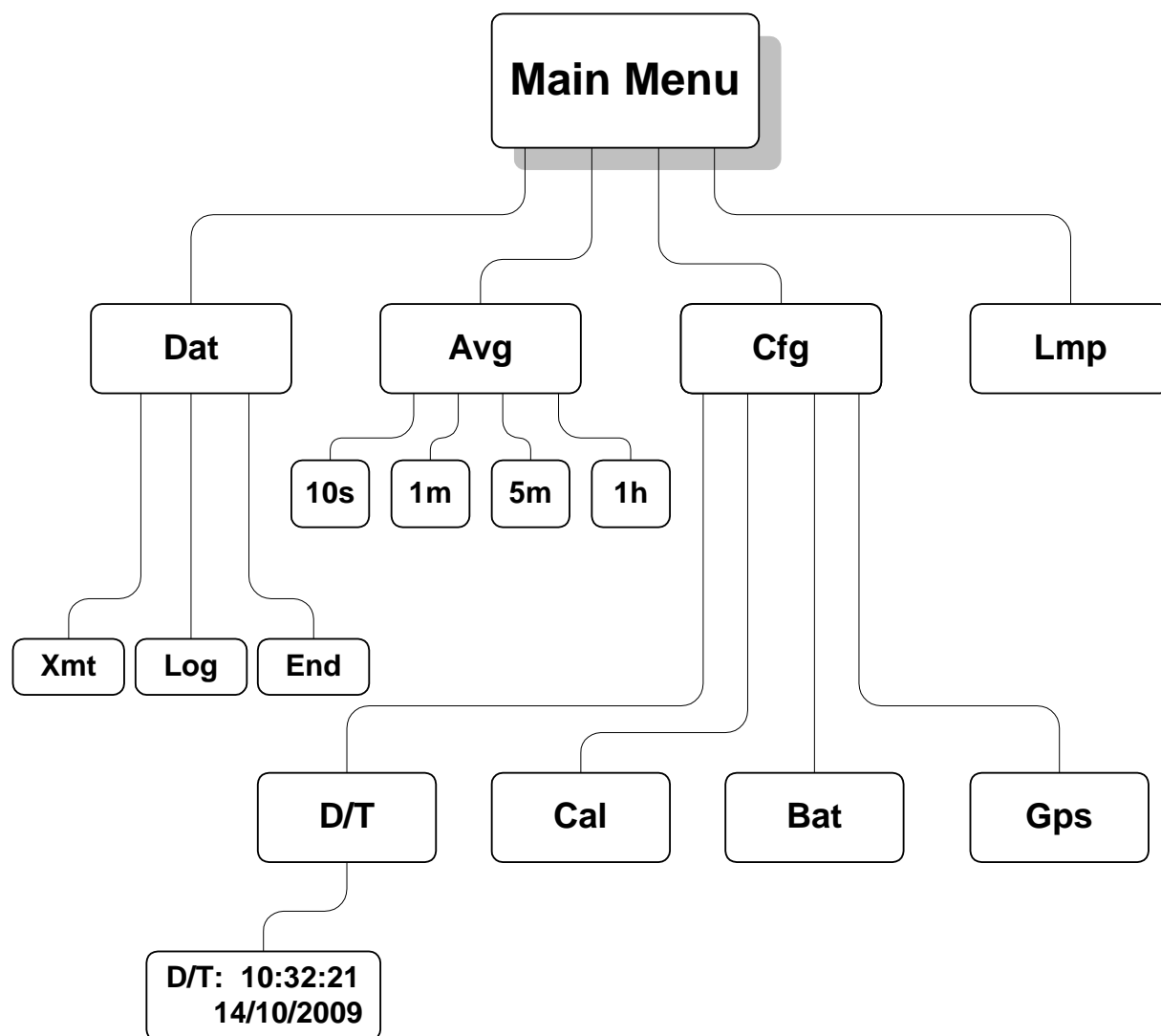

Figure 2. Instrument Menu.

Data Averaging and Data Logging Using the Menu

When first turned on, the instrument will start making measurements at a rate of once every 10 s. Data may be logged in the internal data logger. Up to 8,192 data lines containing log number, ozone mixing ratio, internal cell temperature, internal cell pressure, photodiode voltage, power supply voltage, GPS latitude, GPS longitude, GPS altitude, GPS signal quality, time and date may be stored in internal memory, corresponding to an operational time of 22.75 hours. Averaging times of 1 min, 5 min and 1 hr also may be selected from the menu, thereby increasing the logging capacity to 5.6 days, 28 days and 341 days, respectively, before filling the memory.

Navigating the Front Panel Menu

The front panel consists of a 2 row by 16 character LCD screen and 2 push buttons that are located below the LCD screen (see Fig. 3 below). The curved arrow, or Select button functions to enter and exit menus and for selecting values. The right pointing arrow or Move button functions to move the cursor from left to right.

Entering the Front Panel Menu

The menu is accessed holding the Select button (curved arrow) on the front panel of the instrument. To reach the menu hold in the Select button until

Menu

is displayed, then release the Select button. After a few seconds the menu will appear:

Menu
Dat Avg Cfg Lmp ←

where **Dat**, **Avg**, **Cfg** and **Lmp** are submenus that may be selected. A blinking cursor will show across the **D** of the **Dat** submenu. Clicking on the Move button will move the cursor under the first letter of one of the other submenus. To select a particular submenu, move the cursor under the first letter of a submenu by pressing the Move button and press the Select button to select the submenu. To exit the Main Menu and begin making measurements again, move the cursor to left arrow (←) and press the Select button.

LOGGING DATA

Select the **Dat** submenu from the Main Menu using the Select button. The display will now show:

Dat Menu
Xmt Log End ←

To start logging data, move the cursor to **Log** and click to select the logging mode. You will then receive the prompt:

Overwrite Data?
No Yes ←

Warning: If you start logging, all data previously stored in the logger will be irretrievably lost.

If you have data in the logger that you want to keep, be sure to download it (see below) before starting logging. Select **Yes** if you are sure you want to start logging new data. This will return you to the **Dat Menu**. Select ← to return to the main **Menu**, and select ← again to exit the Menu and start making measurements. Note that “←” always takes you up one level in the menu.

The Personal Ozone Monitor will then alternate every 5 seconds between displaying the most recent 10-s measurement and the current average value. For example, the display might read

O3= 3.2 ppb
T=33.3 P=989.7

where the current 10-s measurement is 3.2 ppb (by volume), the temperature is 33.3 °C and the pressure is 989.7 mbar. If 10-second averaging (no averaging) has been selected, five seconds later, this display might be followed by

O3= 2.2 ppb
19:55 05/02/2010

showing that the time of the measurement is 7:55 pm and the date is 2 May 2010. If averaging has been selected, the above display will be replaced by

Avg O3= 24.1 ppb
19:55 05/02/2010

for example, where the most recent average value of ozone computed is 24.1 ppb. If data are being logged, the log number and number of new

measurements made for the next average (minus 1) are displayed in place of the data and time; e.g.,

Avg O3= 24.1 ppb
Log= 193:4

where **Avg O3** is the average ozone value most recently written to the logger, and the current log number is 193. The “4” in 193:4 refers to the number of 10-s data points that have been measured so far for inclusion in the next average to be displayed and logged. If 1-min averaging is used, this number will increment from 0 to 5; for 5-min averaging, the number will increment from 0 to 29; and for 1-hr averaging, it will increment from 0 to 359. This number is displayed so that the user will know how many more 10-s measurements need to be made before a new average is displayed and logged.

If there is a power failure while the instrument is in the logging mode, logging will resume after power is restored. A note of “Data Interruption” will be written to the logger prior to writing the first new data line. The instrument can accommodate multiple data interruptions due to power failures. For example, one can purposely switch the instrument off, move to another location and restart logging simply by turning the instrument back on. Data sets will be separated by the data interrupt message.

To Stop Logging Data

Hold in the Select button to obtain the **Menu**. Go to the **Dat** submenu by clicking on **Dat**. Select the **End** function. This will end data logging. You may now return to the **Dat** menu to transmit the data to a computer by selecting **Xmt** (see below). The stored data will reside in memory (even when new measurements are being made) and can be transmitted using the **Xmt** function as often as you like.

Note: All stored data are lost once logging is started again using the Log function. Thus, you should always transmit your data to a computer before restarting logging.

If you fail to **End** logging prior to transmitting the data using the **Xmt** function, the instrument will automatically execute the **End** function for you prior to transmitting the data.

To Average Data

Hold down the Select button to obtain the **Menu**. Select **Avg** to obtain the **Avg** menu:

Avg Menu
10s 1m 5m 1h ←

Use the Move button to move the cursor to **10s**, **1m**, **5m** or **1h** for averaging times of 10 s (no averaging), 1 min, 5 min or 1 hr averaging, respectively. Then select the averaging time you want to use. You will be returned to the main **Menu**. To exit the Main Menu and start acquiring data, select ← again.

While in averaging mode, the current 10-s measurement is displayed alternately with the average value at 5-s intervals, as discussed above. Averaged data may be logged, thereby greatly extending the length of time that the data logger can be used.

Capturing the transmitted logged data using the USB or Serial Port

Connect the USB or serial port of the instrument to your computer using the appropriate cable. Enable a data acquisition program on the computer such as the 2B Technologies Display and Graphing Software, which can be downloaded at:

<http://twobtech.com/software.htm>

Alternatively, HyperTerminal can be used (available on most Windows® platforms, usually in Start/All Programs/Accessories/Communications/Hyper Terminal) or Terra Term Pro, which can be downloaded at:

<http://hp.vector.co.jp/authors/VA002416/teraterm.html>

The correct settings for receiving data are: chosen baud rate 19200; 8 bits; no parity; 1 stop bit.

Enter the **Main Menu**. Go to the **Dat** submenu by clicking on **Dat**. Next, select **Xmt**. The message “Logged Data” will be written to the serial port, followed by a carriage return and all of the lines of logged data. After all data are transmitted, the message “End of Logged Data” and a carriage return are written. After transmission is complete, you can return to any position in the menu or resume ozone measurements. The logged data continues to be available for transmission until a new data log is started.

To Set the Calibration Parameters

The instrument is calibrated at the factory where slope (S) and offset (Z) parameters are entered into the instrument's memory. These preset calibration parameters are given in the instrument's Birth Certificate and recorded on the calibration sticker on the back of the instrument. However, the calibration parameters may be changed by the user. Because of noise and/or an inherent offset, some measured values will be below zero at very low ozone mixing ratios or while zeroing the instrument with an external scrubber. Also, the instrument zero may drift by a few ppb over time. For this reason, frequent zeroing of the instrument using an external ozone scrubber to determine the offset is recommended. Any change in the slope (gain) of the instrument is likely due to a serious problem such as contamination, an air leak, obstruction of air flow, or loss of catalytic activity by the internal ozone scrubber, but it also can be adjusted. Once the zero of the instrument is corrected, the slope may be adjusted so that the instrument readout agrees with a standard ozone source (such as the 2B Technologies Model 306 Ozone Calibration Source™) or with the readout from another instrument whose calibration is considered to be accurate.

To change the calibration parameters, choose the **Cfg** submenu from the main **Menu** and click on **Cal** to obtain the display

Cal Menu
Z= -3 S= 1.01

Here Z is the offset applied (in this case -3 ppb) and S is the slope applied (in this case 1.01). The value of Z is added to the measured ozone value, and the value of S is then multiplied by the measured ozone value. During calibration Z is set to 0 and S set to 1.00, if the instrument reads an average of 3 ppb with the external scrubber in place, the value of Z should be set to -3. If after correction for the zero, the instrument consistently reads 2% low, the value of S should be set to 1.02.

When the **Cal Menu** first appears, the **Z** will be underlined with a cursor. You may move the cursor to choose the calibration parameter **S** or **Z**. Selecting **S** or **Z** will select that parameter for change and activate a blinking cursor. Once **S** or **Z** is selected, its value can be changed by pressing the Move button to increase the value. The value will roll-over to negative values after reaching the maximum allowable offset. After choosing the desired value, press the curved arrow to exit stop editing mode. The cursor can then be moved by pressing the right pointing arrow to the **S** to edit the slope or to ← to exit the submenu. Once the values of **Z** and **S** are set, selecting ← will return the display to the **Cfg** menu, and again selecting ← will return to **Menu**. The calibration parameters reside in non-volatile memory and are not affected by power failures.

In order to adjust the zero offset, after the instrument has warmed up for at least 20 minutes attach the external ozone scrubber and make measurements for a few minutes. If the average of those measurements is 4.4 ppb, for example, subtract 4 from the current value of Z; i.e., if Z was set to 3 during the measurements, change Z to -1. For more details about calibrating the Personal Ozone Monitor against another instrument or calibrated ozone source, see the “Calibration” section of this manual or refer to Tech Note No. 15 at: http://www.twobtech.com/tech_notes/TN015.pdf

To Set the Time and Date

From the **Main Menu**, select the **Cfg** submenu. Next, select the **D/T** submenu. The display will read, for example:

D/T: 14:32:21 ←
17/10/2010

meaning that it is 21 seconds after 2:32 p.m. on October 17, 2010 (military time and European date). To change a number in the date and time, move the cursor to underline the numeral you want to change. Pressing the Select button then causes a blinking cursor to cover that numeral. The number can then be changed by pressing the Move button. Once the number is correct, press the Select button to turn off the blinking cursor. You may now use the Move button to choose another numeral to change. Once the time and date is correct, selecting ← will set the internal clock to that time and return the display to the **Cfg** menu. As in setting a digital watch, the seconds should be set in advance of the real time since the clock starts to run again only when the set time is entered; in this case by selecting ←.

Viewing the Power Supply Voltage via the front panel

To view the power supply voltage in real time, select **Bat** from the **Cfg** Menu. Exit this view by pressing the Select button.

Viewing GPS coordinates via the front panel

To view real time Latitude, Longitude and Altitude data, select **GPS** from the **Cfg** Menu. Latitude and Longitude are constantly shown and Altitude is available by pressing and holding the Move button. Exit this view by pressing the Select button.

LAMP TEST

If the instrument is excessively noisy (standard deviation greater than 2 ppb) or always reads near zero in the presence of ozone, it is useful to perform the lamp test to make sure that the lamp is turning on and does not fluctuate too rapidly. Before performing the lamp test, allow the instrument to warm up for at least twenty minutes.

Choose **Lmp** from the main **Menu**. The display will momentarily read "**Lamp Test**". The photodiode voltage will then be displayed, and after a few lamp measurements have been made, the electronic offset and standard deviation also will be displayed as, for example:

PDV= 0.89801 V
1.2+/-1.85 ←

The photodiode voltage (PDV) is a measure of the lamp intensity and should be in the range 0.6-2.2 volts. Since absorbance is a ratio measurement, the absolute value of the voltage is not particularly important. However, above 2.5 volts, which could occur if the instrument is allowed to become too hot, the photodiode is saturated and the calculated ozone concentration will be zero. Photodiode voltage less than 0.6 volts is indicative of either a weak lamp or a dirty detection cell and may result in a noisy measurement. The photodiode voltage will typically increase as the instrument warms up. Lamp drift is continuously monitored and corrected for in the firmware and thus has very little effect on the measured ozone concentration.

Once the instrument is warmed up, fluctuations in photodiode voltage should be limited primarily to the last digit displayed. The lamp test also calculates an electronic offset and standard deviation of the measurement itself, displayed in the above example as 1.2 ppb for the electronic offset and +/-1.85 for the standard deviation. The standard deviation is a quantitative measure of the lamp and associated electronic noise. Electronic offsets should normally be -5 to 5 ppb equivalent. After running the lamp test for a few minutes, values above 2.50 for the standard deviation usually indicate an excessively noisy lamp. Lamps seldom "burn out" but may become noisy with time and need to be replaced. Some lamps become noisy after only a short period, while others will be extremely stable for years. If your lamp fails the lamp test during the first year of operation, contact us for a new lamp under the instrument warranty. Contamination of the detection cell may also cause a high standard deviation, in which case the flow path should be cleaned with methanol and the internal ozone scrubber replaced. Please contact us for detailed procedures if you want to perform these operations on site.

SERIAL MENU

Measurements and logging tasks can be accessed via the serial port or the USB using a terminal emulator such as Tera Term Pro or HyperTerminal running on an attached computer. Commands can be sent using the terminal emulator set with the properties listed in the section of this manual entitled “Collecting Data over the Serial Port in Real Time”. Listed below are the lower case letters that are commands for performing certain operations while the instrument continues to measure:

- l** Start logging and write over existing logged data
- t** Transmit logged data
- e** End logging
- h** Output serial data line header
- m** Serial menu

If the letter **m** is sent as a command, **menu>** will be displayed in the terminal emulator window. When the serial menu is accessed, the instrument is no longer making measurements; it is waiting for the next command to be entered. The following is the list of menu items accessible from this point:

- l** Start logging and write over existing logged data
- t** Transmit logged data
- e** End logging
- h** Output serial data line header
- a** Displays list of possible averaging times and the number that must be entered to change to the desired averaging time
- z** Displays current zero calibration setting and waits for new setting followed by a carriage return
- s** Displays current slope calibration setting and waits for new setting followed by a carriage return
- c** Clock menu, displays current date and time and waits for **d** or **t** to be entered
 - From clock menu,
 - d** Asks to enter date in DDMMYY format
 - t** Asks to enter time in HHMMSS format
- g** Outputs GPS data sentences as read from GPS device
- n** Outputs the serial number of the instrument
- x** Exit menu and return to measuring

MAINTENANCE/TROUBLESHOOTING

The Personal Ozone Monitor is designed to be nearly maintenance-free. The only component that requires routine maintenance is the ozone scrubber, which should be changed at least once every six months of operation. Also, the inlet filter (user supplied) should be changed as recommended by the filter manufacturer.

To change the internal ozone scrubber, remove the top cover by removing the four bolts that hold it in place. The scrubber is connected to the inlet and the “long end” of the solenoid valve (see Figure 6 below). This scrubber can easily be replaced by disconnecting the silicone attached to each end and connecting a new one in its place.

Other components with a limited lifetime are the air pump (~3,000 hours), lamp (~20,000 hours) and solenoid valve (rarely fails). It is recommended that the instrument be returned to 2B Technologies if any of these components fail. Alternatively, the user may install these components at their own risk. In that case, please contact 2B Technologies for instructions.

The following are indications of various instrument malfunctions.

Air Pump Failure: The instrument will not make a humming sound. Also, the circuit breaker may prevent the instrument from powering up if the motor in the air pump develops a short.

Lamp Failure: The ozone measurements will be erratic and the Lamp Test will show 0.0 volts for the photodiode voltage.

Solenoid Valve Failure: The ozone readings will be low and average to close to zero if the solenoid valve is not switching. Partial switching of the solenoid valve will cause the instrument to read low but not zero.

Contaminated Flow Path: The instrument will typically have a large positive or negative offset, and the ozone readings will be low once corrected for the measured offset.

Help with trouble shooting is provided in the following table. Corrective actions listed may be performed by the user; however, we recommend first contacting 2B Tech for more detailed instructions or returning the instrument for repairs.

Table I. Troubleshooting the Personal Ozone Monitor for performance problems.

Problem/symptom	Likely cause	Corrective action
<i>Instrument does not turn on.</i>	Power not connected properly or circuit breaker open.	Check external power connection for reverse polarity or a short and wait a few minutes for the thermal circuit breaker to reset.
<i>Instrument turns on then powers off.</i>	Burned out air pump.	Remove top cover and unplug air pump. Turn instrument on; if it remains running, then the air pump motor is burned out and shorting. Replace air pump.
<i>Readings are noisy with standard deviations greater than 2.5 ppb.</i>	Lamp output is weak, below 0.6 V on Lamp Test.	Remove top cover and check lamp connection to circuit board. Run Lamp Test from menu. If photodiode voltage is less than 0.6 V, replace lamp.
	Flow path contaminated.	Clean flow path with methanol according to the Cleaning Procedure.
<i>Required calibration parameters are large (>±9 ppb offset and/or >±9% slope) when calibrated using a standard ozone source or reliable ozone instrument.</i>	Ozone scrubber is contaminated.	Replace ozone scrubber. Be sure to use an inlet filter to remove particulate matter.
	Flow path is contaminated.	Clean flow path with methanol following the Cleaning Procedure.

	<p>Solenoid valve is contaminated and not opening and closing properly.</p> <p>Air pump is not drawing sufficient flow.</p>	<p>Remove top cover, unplug pump, turn instrument on and listen for clicking of solenoid valve every 2 seconds. If solenoid valve is clicking, remove tubing connections and test solenoid valve to confirm that air always flows through common and alternately through normally open and normally closed states.</p> <p>Replace solenoid valve if not working properly. This requires soldering.</p> <p>As a first check, hold your finger over the air inlet to determine whether air is being drawn in. If there is flow, measure the flow rate by attaching a high conductance flow meter to the air inlet. Air flow should be greater than 0.6 L/min. If flow is lower, check for leaks. If there are no leaks, replace air pump.</p>
--	---	---

2B Technologies offers reasonably priced customer service for instrument repairs. The calibration service includes cleaning of the entire flow path with methanol, testing of all components for proper function, installation of a new internal ozone scrubber and calibration against a NIST-traceable standard. The best way to contact us for service is to log a customer service ticket at www.twobtech.com/techsupport. Normally, you will hear back from us by email within a few hours. Or, call us at +1(303)273-0559.

There is a great deal of technical information about our instruments posted as technical notes at www.twobtech.com/tech_notes.htm. Manuals, brochures, software, cleaning procedures and scientific papers may be downloaded at www.twobtech.com/downloads.htm.

CALIBRATION

Every analytical instrument is subject to some drift and variation in response, making it necessary to periodically check the calibration. Dynamic calibration is a multipoint check where gas samples of known concentrations are sampled by the instrument in order to determine a calibration relationship. For more information on calibration of ozone monitors refer to the Code of Federal Regulations (Title 40, Part 50, Appendix D) and the EPA's Technical Assistance Document for the Calibration of Ambient Ozone Monitors.

Calibration is the process of adjusting the gain and offset of the Personal Ozone Monitor against some recognized standard. The reliability of the data collected from any analytical instrument depends on the accuracy of the calibration, which is largely dependent upon its analytical traceability to a reference material or reference instrument calibration.

Because of the instability of ozone, the certification of ozone concentrations in a compressed gas cylinder is impossible due to loss of ozone over time. When ozone concentration standards are required, the ozone must be generated and certified on site. The following are based on EPA requirements for calibrations of ozone monitors for monitoring in compliance with the Clean Air Act. Similar procedures are recommended for other applications as well.

Ozone standards can be classified into two basic types:

1. A **Primary Ozone Standard** is the combination of an ozone generator and an ozone monitor based on UV absorbance (a UV photometer) that has been setup in accordance with the procedures prescribed by the U.S. Environmental Protection Agency (EPA) under Title 40 of the Code of Federal Regulations, Part 50, Appendix D (40 CFR Part 50).
2. An **Ozone Transfer Standard** is a system (a portable ozone monitor and/or a portable ozone generator), which can produce accurate ozone concentration standards which are quantitatively related to a primary ozone standard. An example of an ozone transfer standard is the 2B Technologies Model 306 Ozone Calibration Source. Ozone transfer standards must be certified before use in accordance with the procedures prescribed by the

U.S. Environmental Protection Agency (EPA) under Title 40 of the Code of Federal Regulations, Part 50, Appendix D (40 CFR Part 50).

Equipment Required

The equipment that is needed to carry out the calibration is commercially available, or it can be assembled by the user. Calibration using a primary ozone standard involves the generation of ozone concentrations that are simultaneously measured by a primary ozone standard and the instrument undergoing calibration. This procedure requires the following equipment:

1. Zero air source
2. Ozone generator
3. Sampling manifold (inert material such as PTFE or FEP only)
4. Sampling lines (inert material such as PTFE or FEP only)
5. UV Photometer

Use of a certified transfer standard for calibration involves the generation of ozone concentrations, using the calibrated ozone generator, that are measured by the instrument undergoing calibration. This procedure requires the following equipment:

1. Zero air source
2. Certified Transfer Standard
3. Sampling manifold (inert material such as PTFE or FEP only)
4. Sampling lines (inert material such as PTFE or FEP only)

Zero air can be generated either from compressed cylinders or from scrubbed ambient air. If ambient air is used, contaminants such as ozone and nitric oxide must be removed. Detailed procedures for generating zero air are in the EPA's Technical Assistance Document for the Calibration of Ambient Ozone Monitors.

Instrument Preparation

Prior to calibration, follow the steps below:

1. Turn on the Personal Ozone Monitor and allow it to stabilize for a minimum of one hour.
2. Connect the instrument to the manifold on the ozone calibration setup. If a particle filter will be used in normal operation, the calibration must be performed through the filter. The manifold must

-
- be vented to atmosphere so that pressure does not build up in the calibration setup. Connection of the POM directly to a pressurized output of any device can damage the Personal Ozone Monitor.
3. Verify that the flow rate into the manifold is greater than the total flow required by the instrument and any other flow demand drawing from the manifold.

Calibration Setup Preparation

As indicated in the EPA Technical Assistance Document there are several tests that should be performed prior to calibration to ensure the accuracy of the measurements. These tests include:

- Setup check
- Ozone loss test
- Linearity check
- Intercomparison test

Setup Check

A visual inspection of the calibration setup should be performed before calibration to verify that the setup is in proper order. All plumbing connections should be checked and verified to follow the manufacturer's instructions. Any obvious leaks should be fixed and the manifold and sampling lines should be checked for general cleanliness. For more information refer to the manufacturer's User Manual for the primary ozone standard or ozone transfer standard.

Ozone Loss Test

Some ozone may be lost in the calibration setup due to reaction with the walls of the manifold and sampling lines. Any significant loss of ozone must be measured and be subsequently applied to correct the calibration measurements. For more information refer to the manufacturer's User Manual for the primary ozone standard or ozone transfer standard.

Linearity Check

Since the Personal Ozone Monitor is inherently linear over several orders of magnitude, a linearity check provides a test that the instrument is operating properly. Instrument linearity can be checked by comparison to an ozone standard (see Calibration Procedure – Calibration Curve) or by dilution of an ozone measurement. To check the instrument linearity by dilution of an ozone measurement, generate and measure a concentration of ozone near the upper

range of ozone concentrations to be measured using the POM. Additional ozone concentrations should be generated by accurately diluting the ozone flow with zero air and each concentration should be measured once the instrument reaches a stable response. The accuracy of the linearity test relies on the accuracy of the flow meters used to perform the dilution. The percent of non-linearity is calculated from the formula:

$$R = \frac{F_o}{F_o + F_d} \quad (2)$$

$$E = \frac{C_1 + \frac{C_2}{R}}{C_1} \times 100\% \quad (3)$$

where:

- R = Dilution ratio
- F_o = Ozone generator flow
- F_d = Diluent zero air flow
- E = Linearity error, in percent
- C₁ = Measured concentration of original concentration
- C₂ = Measured concentration of diluted concentration

The linearity error should not be greater than 5%. If the error is greater than 5%, the accuracy of the flow dilution should be checked before assuming that the instrument is not linear. Note that the inherent linearity of the POM is better than the error calculated in this linearity check due to the uncertainty introduced by the flow measurements.

Intercomparison Test

Comparison of the calibration setup with other ozone standards is a good check of the overall accuracy of the setup. If measurements from another ozone standard are found to deviate from the calibration setup greater than the instrument specifications, one of the calibration setups is not accurate.

CALIBRATION PROCEDURE

A multipoint calibration should be performed within the calibration frequency, any time major disassembly of components is performed, or any time the zero or span checks give results outside of the acceptable limits.

Instrument Preparation

-
1. Turn on the Personal Ozone Monitor and allow it to stabilize for a minimum of one hour.
 2. Enter the calibration menu (**Main Menu\Cfg\Cal\O3**) and set the zero (Z) value to 0 and the slope (S) value to 1.00.
 3. Connect the Personal Ozone Monitor to the manifold on the ozone calibration setup. If a particle filter will be used in normal operation, the calibration must be performed through the filter. The manifold must be vented to atmosphere so that pressure does not build up in the calibration setup. Connection of the POM directly to a pressurized output of any device can damage the instrument.
 4. Verify that the flow rate into the manifold is greater than the total flow required by the Personal Ozone Monitor plus any other flow demand drawing from the manifold such as a UV photometer or ozone transfer standard.

Measurement of Zero Air

1. Verify that the zero air supply is on and the ozone generator is off. The same zero air supply used in the ozone generator must be used in the ozone generator.
2. Allow the POM to sample zero air until the response is stable.
3. Record the average zero air response.

Measurement of Ozone Standards

1. Generate an ozone concentration slightly less than the concentration range of interest and allow the ozone generator to warm up for at least 5 minutes. The same zero air supply used for making zero air measurements must be used in the ozone generator.
2. Allow the Personal Ozone Monitor to sample the ozone concentration standard until a stable response is measured.
3. Record the average response of the Personal Ozone Monitor as well as either the average response of the UV photometer the transfer standard.
4. Generate several other ozone concentration standards. At least 5 ozone concentration standards are recommended over the range of interest.
5. For each ozone concentration standard, record the response of the Personal Ozone Monitor as well as either the response of the UV photometer or the transfer standard.

Calibration Curve

1. Plot the POM Monitor responses (x-axis) versus the corresponding standard ozone concentrations (y-axis).

-
2. Fit the data to a straight line ($y = mx + b$) using the linear regression technique to determine the calibration relationships.
 3. Determine if any points deviate significantly from the line, which is an indication of an error in determining the calibration curve. The error may be due to the calibration setup or the Personal Ozone Monitor being calibrated. The most likely causes of problems for the POM are leaks, a malfunctioning ozone scrubber, a contaminated valve, or contamination in the optical setup. See the “Troubleshooting” section of the manual.
 4. The slope of the line is the gain factor (S) and the intercept is the offset (Z) that need to be applied to the instrument response to calibrate it to the primary ozone standard. If the intercept is outside of the range from -10 to 10 or the slope is outside of the range from 0.90 to 1.10, this is an indication of a problem in the calibration setup or the instrument being calibrated. The most likely cause of errors in the POM are leaks, a malfunctioning ozone scrubber, a contaminated valve, or contamination in the optical setup. See the “Troubleshooting” section of the manual.
 5. Enter the calibration menu (**Main Menu\Cfg\Cal**) in the instrument firmware and set the calibration parameters.

PERIODIC ZERO AND SPAN CHECKS

To ensure the quality of the Personal Ozone Monitor data, periodic zero and span checks can be performed by following the steps below:

1. A zero check is performed by sampling zero air with the POM following the “Measurement of Zero Air” section above.
2. A span check is performed by sampling an ozone concentration at the high end of the concentration range of interest following the “Measurement of Ozone Standards” section above.
3. Average measurements from the zero check or span check should be within the instrument specifications. If the measurements are not within specifications, this is an indication of problem in the calibration setup or the POM being checked. The most likely causes of problems in the POM are leaks, a malfunctioning ozone scrubber, a contaminated valve, or contamination in the optical setup. See the “Troubleshooting” section of the manual.

LABELLED PARTS

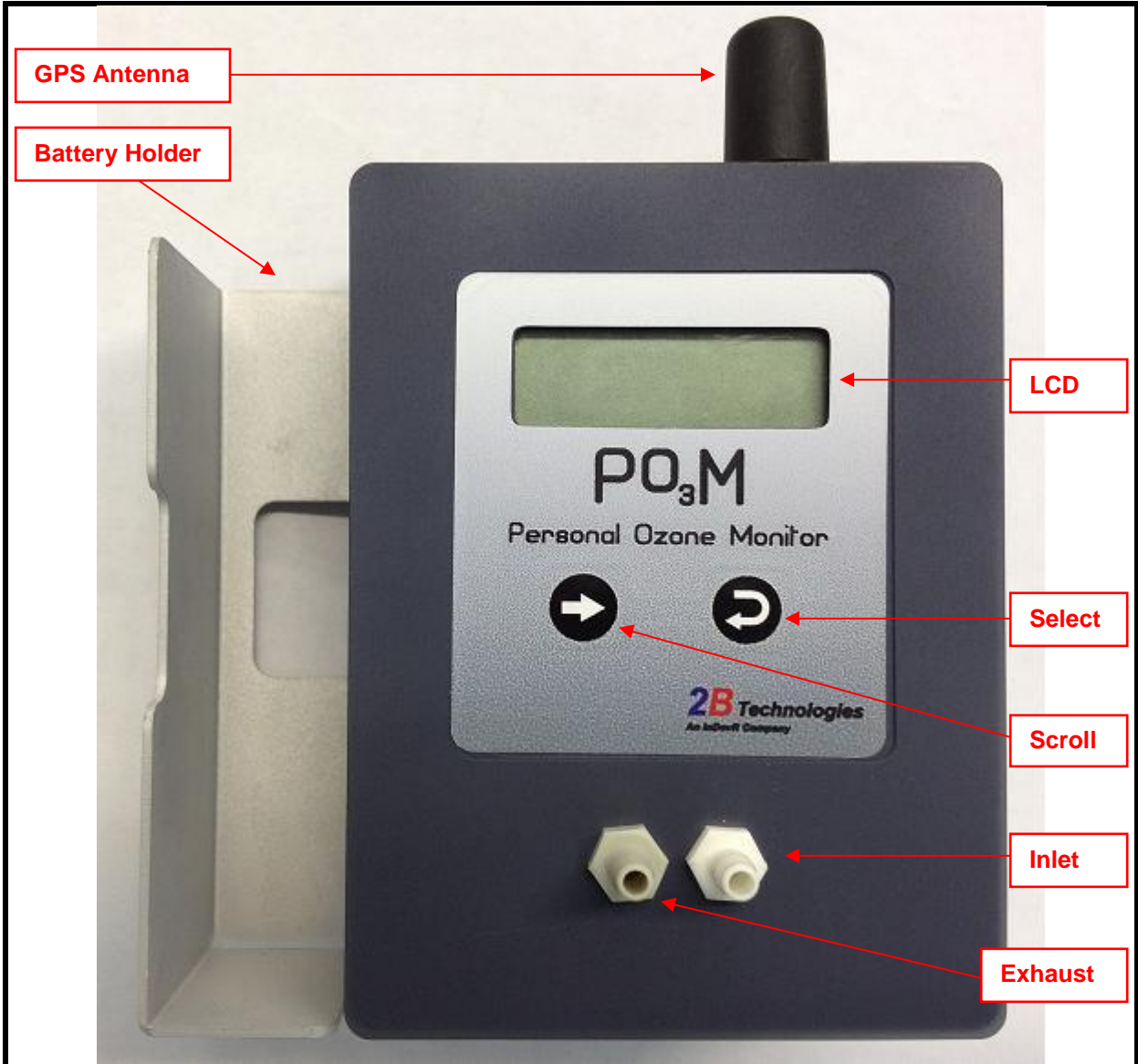

Figure 3. Front Cover of the POM.

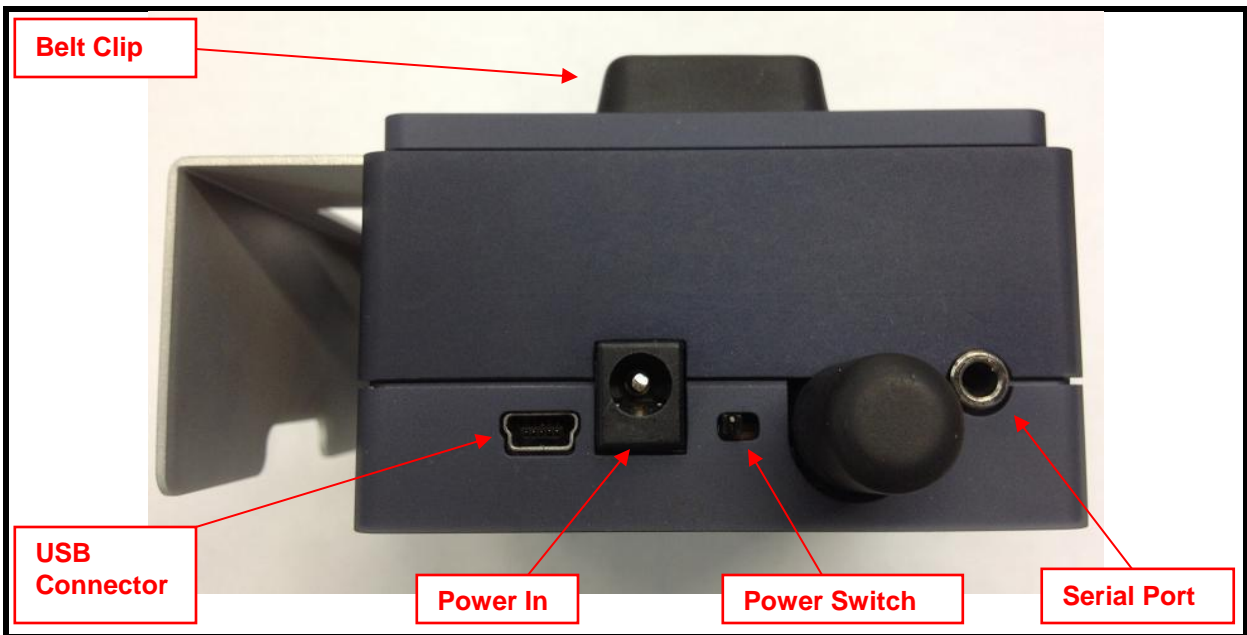

Figure 4. Top View.

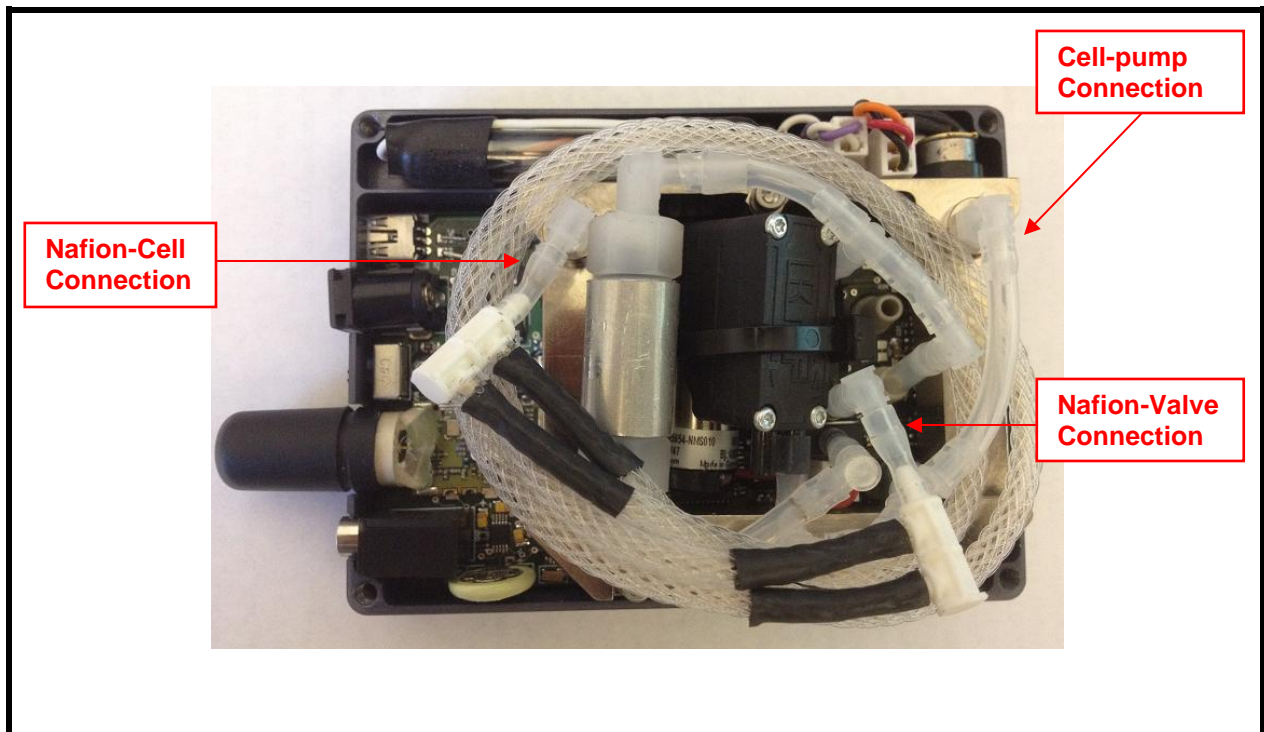

Figure 5. Inside View.

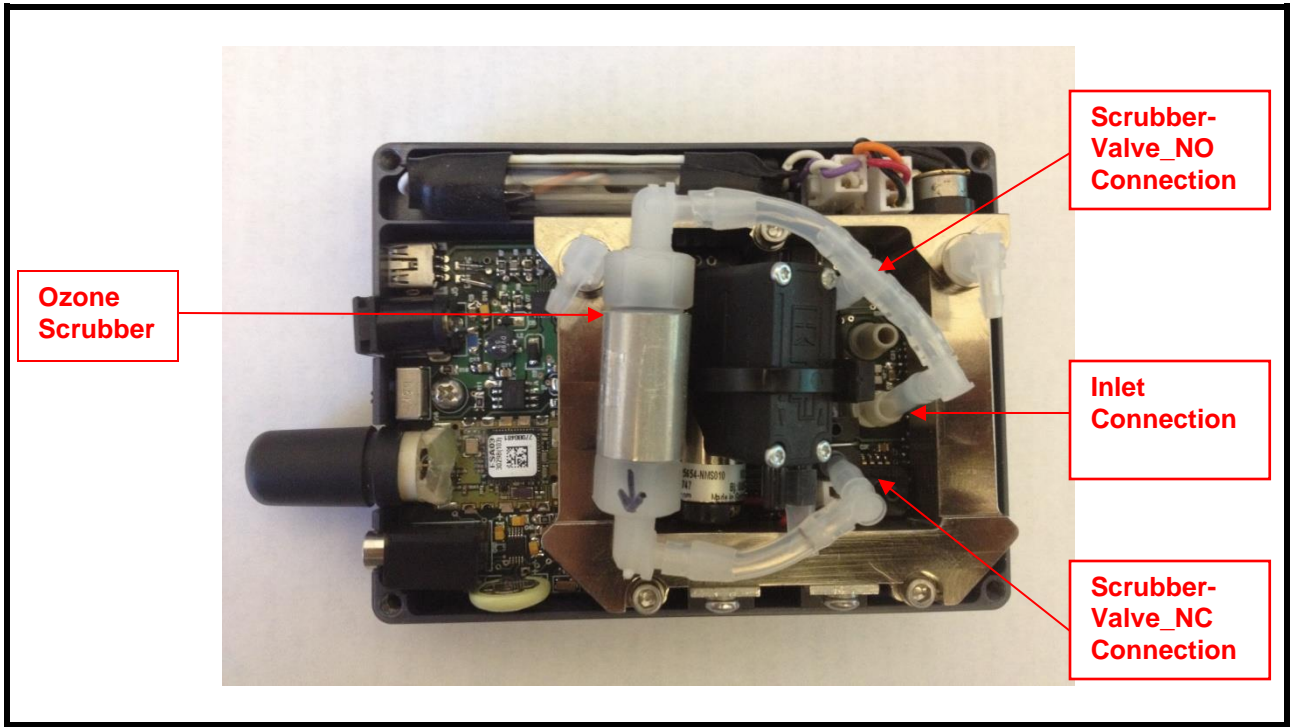

Figure 6. Inside view without Nafion.

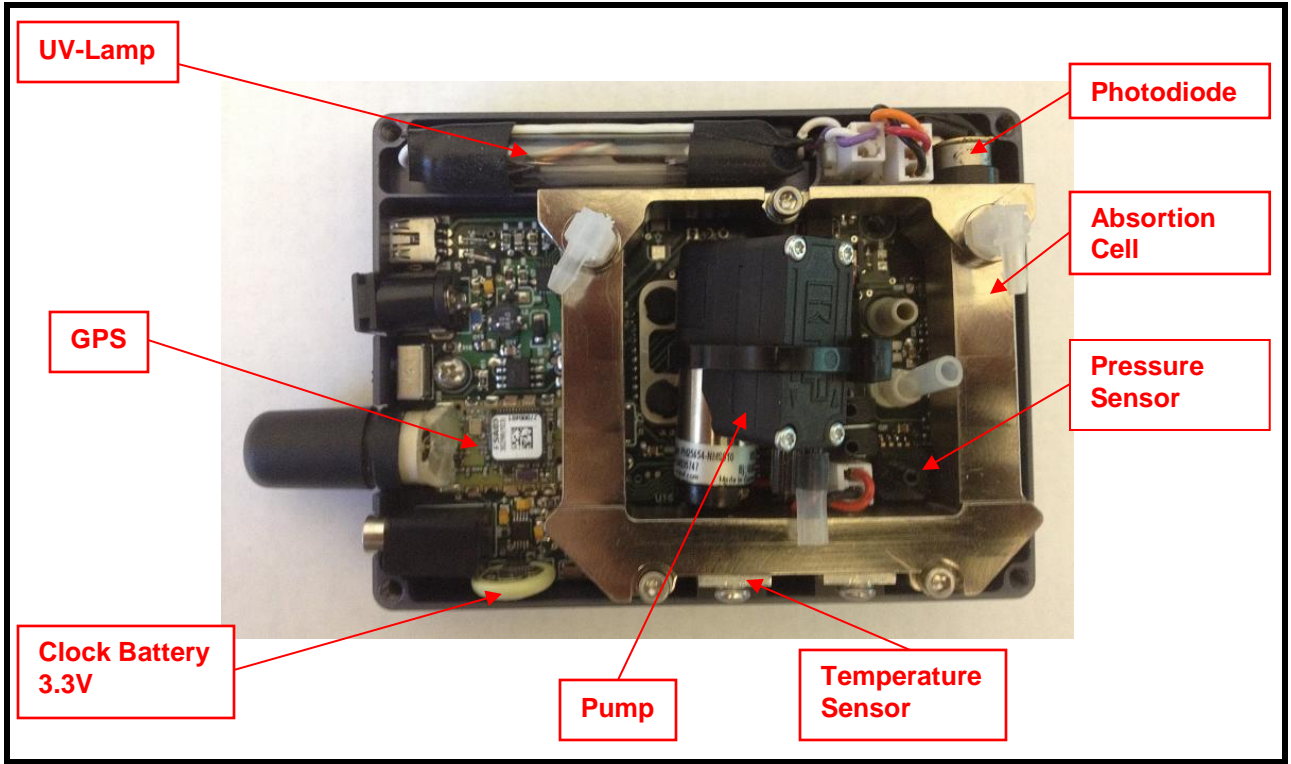

Figure 7. Inside view without Scrubber or Nafion.

PARTS LIST

The following list includes those parts that are user serviceable. They may be ordered online from 2B Technologies from our website here: <http://twobtech.com/shop.html> Or, contact us at sales@twobtech.com.

Part Number	Description
SCRBINTPOM	Ozone scrubber (internal)
ZEREXTPOM	Ozone zeroing scrubber (external)
OZLAMPPOM	Lamp and inverter
OZPUMPPOM	Air pump
PDASSYPOM	Photodiode assembly
OZCELPOM	Absorption cell
SERCABLPOM	Serial port cable (to computer)
USBCABL	USB Cable
12VADP	12 V DC cigarette lighter adapter
TEFTYG	Teflon-lined Tygon® tubing
SILTUB	Silicone tubing

SERVICE LOG

Date/ Hours	Calibrated	Cleaned	New O ₃ Scrubber	New Pump (main)	New Lamp	Other

Date/ Hours	Calibrated	Cleaned	New O₃ Scrubber	New Pump (main)	New Lamp	Other

USB INSTALLATION

The following procedure describes how to install the USB connection for the Model Personal Ozone Monitor.

Items Required

1. Personal Ozone Monitor
2. USB Cable (supplied with POM)
3. PC Computer with Windows 2000, XP, Vista, 7 or 8
4. USB to UART Driver Disk (or download from 2B Tech website here: http://twobtech.com/downloads_software.htm)

Driver Installation

1. Insert USB to UART Driver Disk in the computer's CD ROM drive or download the Model POM USB Driver from the 2B Tech website.
2. The installation files are located in a zip folder. Navigate to the folder labeled "cdc_NTXP" and double click on it.
3. Unzip the contents to a folder on the desktop or any area you wish.
4. With the POM off, attach USB cable from the POM to a USB port on the computer.
5. Turn on POM. The install wizard should pop up as follows. Select "No, not this time" and click "Next".



-
6. Select the “Install from a specific location” option and click “Next”.

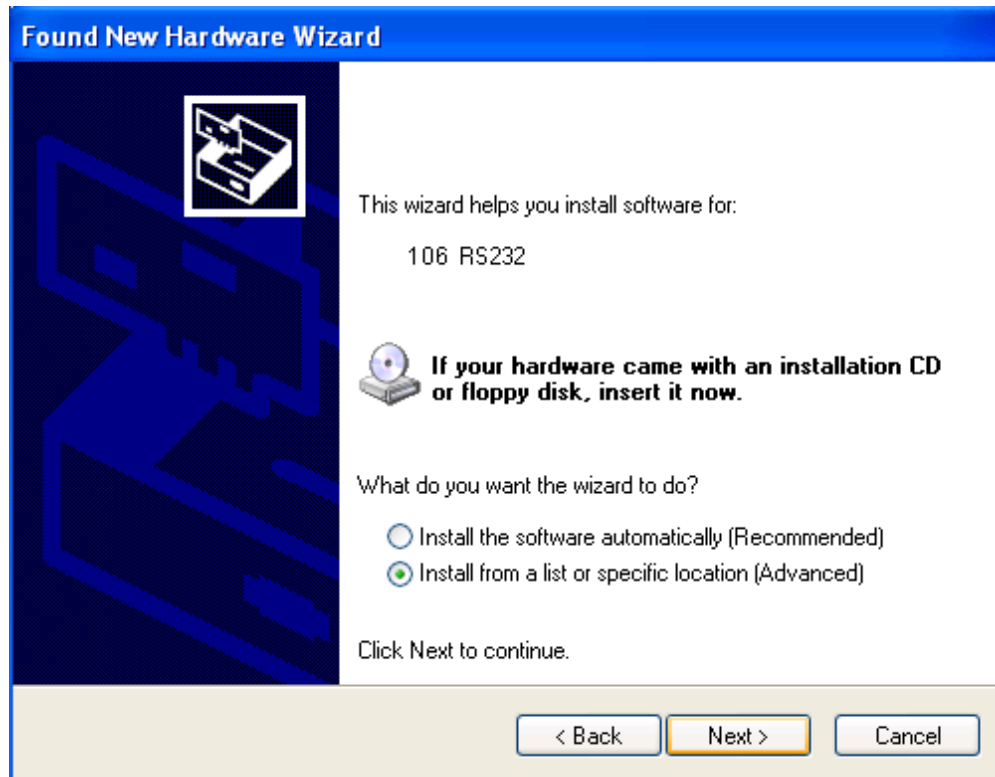

7. Navigate to folder where you unzipped the cdc_NTXP.

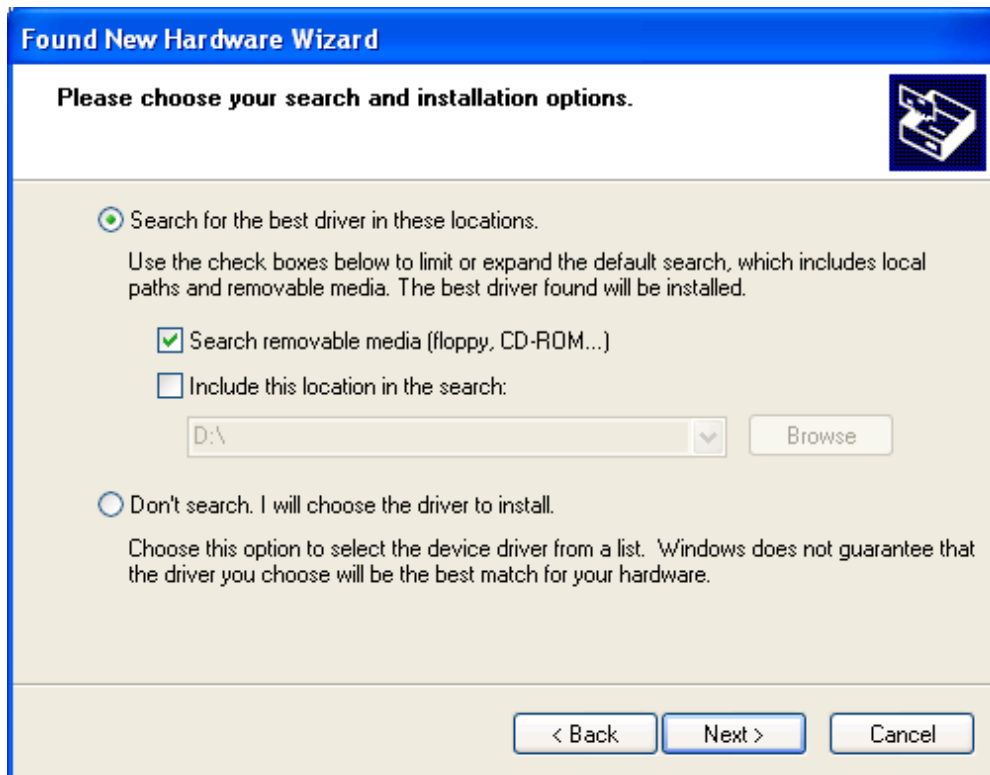

8. Select “Continue Anyway” when this window appears.



9. After a few seconds, the driver will be finished installing.

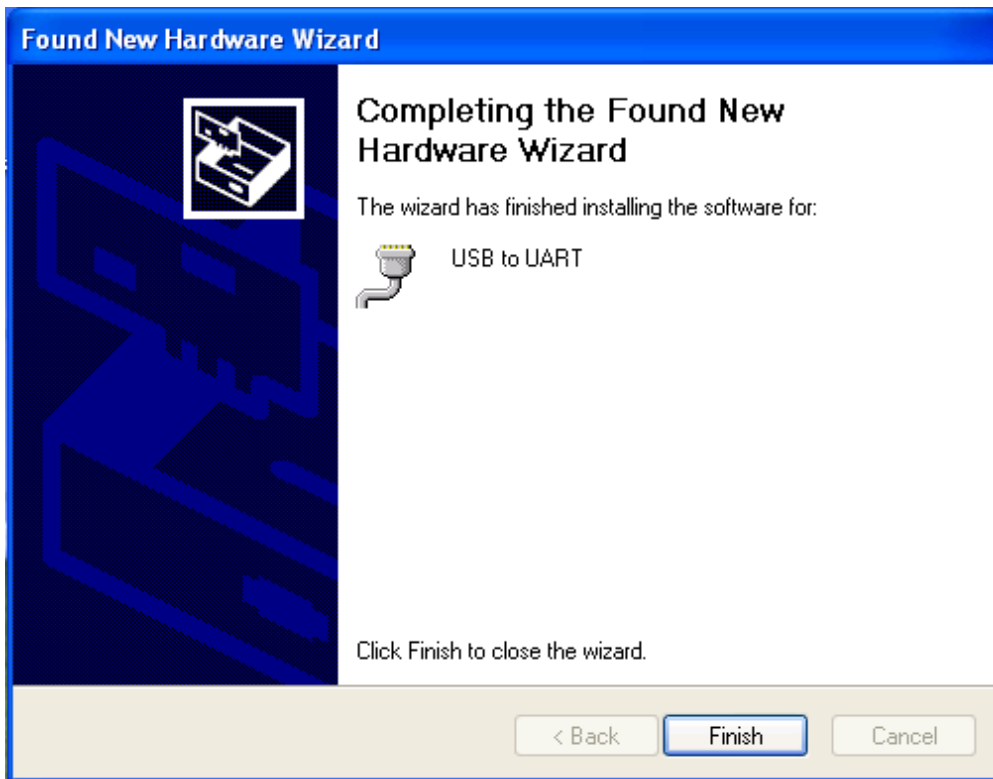

USING THE USB CONNECTION

Determine the connection port

After installation is complete, determine which COM port the connection is using. This can be done by the following procedure.

1. If using Windows (XP, Vista, 7), go to the control panel and select “System”.
2. Click on the “Hardware” tab.

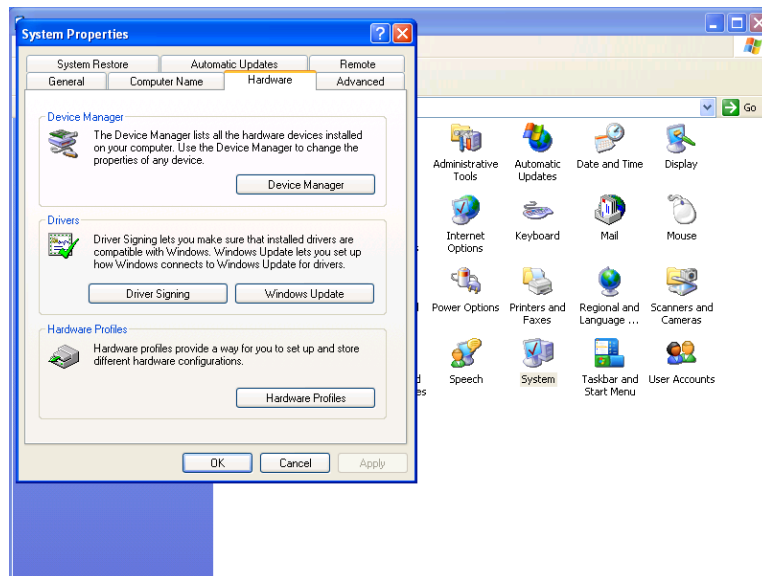

3. Click the “Device Manager” button.
4. Press the “+” sign next to “Ports”.

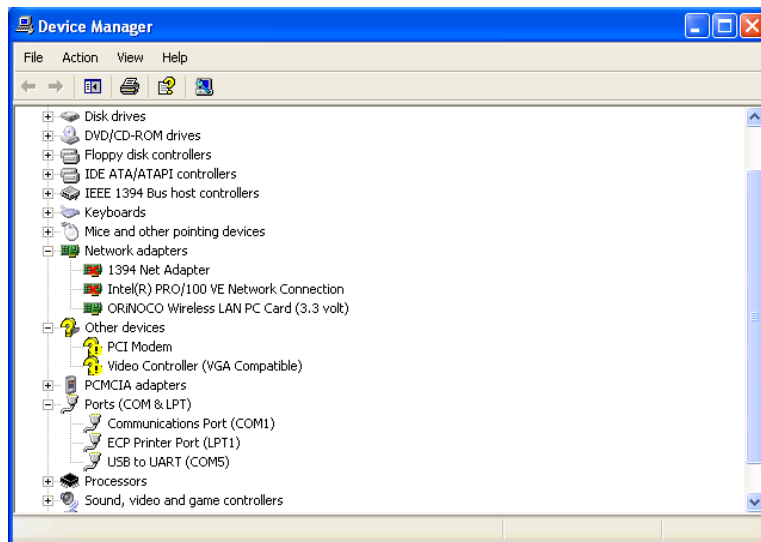

5. In Parenthesis, next to the “USB to UART” listing is the assigned COM port number. This number will be used for the settings for the 2B Tech software or terminal emulator used to read data from the POM.

Using the Connection

- Plug the USB cable in after the powering the POM to ensure correct functionality.
- When setting up your software or terminal emulator, choose the correct com port listed in the Device manager.
- Use these baud rate settings: 19200, 8 bits; no parity; 1 stop bit.
- Use 2B Technologies Display and Graphing Software (free download from <http://twobtech.com/software.htm>) to read measurement data from the POM.